

# E1T Expansion Relay

## More Outputs

By connecting expansion relays to a safety relay it is easy to increase the number of safe outputs. This means that an unlimited number of dangerous machine operations and functions can be stopped from one safety relay/PLC.

## Safe Soft Stop

When a gate is opened a program stop is first given to the machine's PLC/servo which brakes the dangerous operations in a soft and controlled way. The safety outputs then break the power to the motors, that is, when the machine has already stopped. Normally between 0.5 and 1 second is needed to brake a dangerous machine operation softly. Soft stop ensures many advantages:

- The machine lasts longer.
- Parts being processed are not damaged.
- Restart from stopped position is enabled and simplified.

A safe soft stop is achieved by means of a safety relay which gives the program stop, and an expansion relay, E1T, which gives safe delayed stop signals. See chapter "Connection Examples". The drop time delay on a E1T can be from 0 to 3 seconds depending on the model. By connecting several E1Ts in series even longer times can be achieved.

## Safety Level

The E1T has twin stop functions, that is, two relays with mechanically operated contacts. A monitored stop function is achieved by connecting the test output (terminals X1 and X2) to the test or reset input on the safety relay which is being expanded.

One condition for a safe delayed stop is that the delay time cannot increase in the event of a fault. The E1T complies with this requirement.

## When are delayed safe stops used?

Delayed safety stop signals can be used for emergency stops according to EN ISO 13850:2008 § 4.1.4. Stop category 1 and NFPA 79, i.e. a controlled stop with power to the actuator(s) available to achieve the stop and then removal of power when stop is achieved.

Stop category 1 may also be permitted when it is not possible to gain physical access to the machine before the safe stop is affected e.g:

- Gates, access time is normally over 1 sec.
- Covers and gates which are locked until dangerous operations and functions have been stopped.
- Long distances between a safety device and a dangerous machine function.



## Applications

- More Safety Outputs
- Delayed Safety Outputs
- Output Contact Indication

## Features

- Width 22.5 mm
- LED indication of output
- 4 NO relay outputs
- 24 VDC
- Single or dual channel operation option
- Quick release connector blocks

## Connection Examples

For examples of how our safety relays can solve various safety problems, see "Connection Examples" beginning on page 5:44.

## Regulations and Standards

The E1T is designed and approved in accordance with appropriate directives and standards. See Technical Data.

## Approvals

TÜV Nord  

## E1T Technical Data

Manufacturer	ABB AB/Jokab Safety, Sweden
Ordering information	see page 5:65
Color	Grey
Operational voltage	24 VDC ± 15%
Power consumption	1.5 W
Relay outputs	4 NO
Maximum switching capacity	
Resistive load AC	6A/250VAC/1500VA
Inductive load AC	AC15 240VAC 2A
Resistive load DC	6A/24VDC/150W
Inductive load DC	DC13 24VDC 1A
Max. total switching capacity	12A distributed on all contacts
Minimum switching load	10 mA/10 V (if load on contact has not exceeded 100 mA)
Contact material	Ag + Au flash
Fuses output (external)	5A gL/gG
Conditional short-circuit current (1 kA)	6A gG
Maximum external resistance at a nominal voltage	150 Ohm (S14, S24)
Response time at deactivation (input-output)	< 0,020 s, 0,5 s, 1 s, 1,5 s, 2 s, 3 s, ± 20%
Response time at activation (input-output)	<30 ms
Terminals (max. screw torque 1 Nm)	
Single strand	1x4 mm <sup>2</sup> /2x1.5 mm <sup>2</sup>
Conductor with socket contact	1x2.5 mm <sup>2</sup> /2x1 mm <sup>2</sup>

Mounting	35 mm DIN-rail
Protection class	
Enclosure	IP 40 IEC 60529
Terminals	IP 20 IEC 60529
Impulse withstand voltage	2.5kV
Pollution degree	2
Operating temperature range	-10°C – +55°C (with no icing or condensation)
Operating humidity range	35% to 85%
LED indication	Output status
Weight	220 g
Performance (max.)	Category 4/PL e (EN ISO 13849-1:2008)
Functional test	SIL 3 (EN 62061:2005)
The relays must be cycled at least once a year	PFH <sub>d</sub> 1.55E-08
Conformity	2006/42/EC, 2006/95/EC 2004/108/EC EN 954-1:1996, EN 62061:2005 EN ISO 13849-1:2008

**Note:**  
Connector blocks are detachable without cables having to be disconnected.

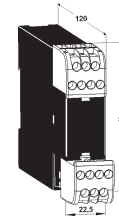

## E1T Technical Description

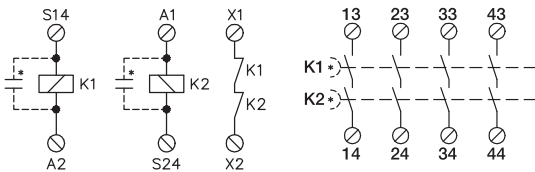

operation - see below.) When the inputs S14 and S24 close, relays K1 and K2 are activated. A stop signal is given, K1 and K2 drop, if the inputs are opened or during power failure. K1 and K2 drop either directly or after a delay\* (if

incorporated). Delay time of module is fixed and shown on front panel of device. The delay circuit is arranged so that the design time cannot be exceeded.

To check that both the relays K1 and K2 drop during a stop signal they must be monitored. This is achieved by connecting

X1 and X2 to the test or reset input on the safety relay which is expanded (see below). K1 and K2 are mechanically operated relays, therefore, if one of the output contacts should stick closed then the relay's contact in X1-X2 cannot be closed thus preventing a new ready signal being given to the safety relay.

Inductive loads should be equipped with an arc suppressor to protect the output contacts.

Diodes are the best arc suppressors but will increase the switch off time of the load.

The E1T has to be connected to a safety relay in order to fulfill the necessary safety requirements (see connection examples below). The safety relay controls and monitors the E1T. (The E1T can be connected for single or dual channel

## E1T Electrical Connections

Single channel expansion of outputs for a safety relay connected to an emergency stop.

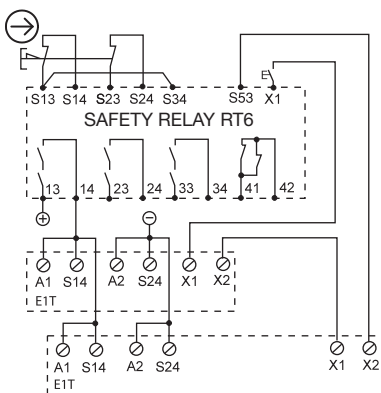

Dual channel expansion with delayed safety outputs for a safety relay monitoring a gate.

